



**DESIGN TECHNOLOGY
STANDARD LEVEL
PAPER 3**

Thursday 13 May 2010 (morning)

1 hour

Candidate session number

0	0								
---	---	--	--	--	--	--	--	--	--

INSTRUCTIONS TO CANDIDATES

- Write your session number in the boxes above.
- Do not open this examination paper until instructed to do so.
- Answer all of the questions from one of the Options in the spaces provided. You may continue your answers on answer sheets. Write your session number on each answer sheet, and attach them to this examination paper and your cover sheet using the tag provided.
- At the end of the examination, indicate the letters of the Options answered in the candidate box on your cover sheet and indicate the number of answer sheets used in the appropriate box on your cover sheet.



Option A — Food science and technology

A1. Olive oil is a natural product which is a complex mixture of fatty acids, vitamins, volatile components, water soluble components and small bits of olive. The fatty acids contained in olive oil are unsaturated fatty acids – oleic, linoleic and linolenic.

- Oleic acid is monounsaturated and makes up 55–85% of olive oil

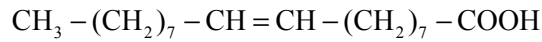

- Linoleic acid is polyunsaturated and makes up about 9%

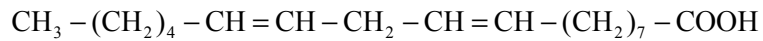

- Linolenic acid is also polyunsaturated and makes up 0–1.5%

Figure A1: Olive oil



[Source:http://en.wikipedia.org/wiki/File:Italian_olive_oil_2007.jpg]

(a) Define *unsaturated fatty acid*. [1]

.....

.....

(b) Describe the importance of unsaturated fats to health. [2]

.....

.....

.....

(This question continues on the following page)



(Question A1 continued)

- (c) Explain the importance of unsaturated fatty acids in the development of rancidity and the shelf life of cooking oils. [3]

.....

.....

.....

.....

- A2.** (a) Define *lifestyle*. [1]

.....

.....

- (b) Identify **one** lifestyle factor which affects food choice and impacts on health. [2]

.....

.....

.....



A3. Created in 1886 by Dr John S Pemberton, the Coca-Cola brand has become one of the most widely recognised globally. Since 1982 the Coca-Cola company has developed a wide range of products to meet the needs of different market segments (see **Figure A2**). These include a cherry-flavoured product, low sugar products (diet Coke and diet Coke caffeine free) and no sugar products (Coca-Cola Zero). Most recently, Coca-Cola have produced “diet Coke plus” products – diet Coke plus vitamins and diet Coke plus antioxidant.

Figure A2: The Coca-Cola product family (original, cherry flavour, diet Coke, diet Coke caffeine free, Coca-Cola Zero, diet Coke plus vitamins and diet Coke plus antioxidants)

IMAGE REMOVED DUE TO COPYRIGHT REASONS.

(a) List **two** functions of the packaging of Coca-Cola. [2]

.....
.....
.....

(b) Outline **one** way in which the packaging of Coca-Cola has contributed to the development of the Coca-Cola brand. [2]

.....
.....
.....

A4. Outline **one** way in which food can influence the incidence of cancer. [2]

.....
.....
.....



Option B — Electronic product design

B1. A digital control system is used to activate a garden irrigation system (see **Figure B1**). The moisture sensor provides logic 1 when the soil is too dry for the plants to remain healthy. The temperature sensor provides logic 1 when the temperature exceeds 25°C. The irrigation system is activated by logic 1. The irrigation system needs to be activated when the soil is too dry for the plants, but only if the temperature is less than 25°C.

Figure B1: Digital control system to activate a garden irrigation system

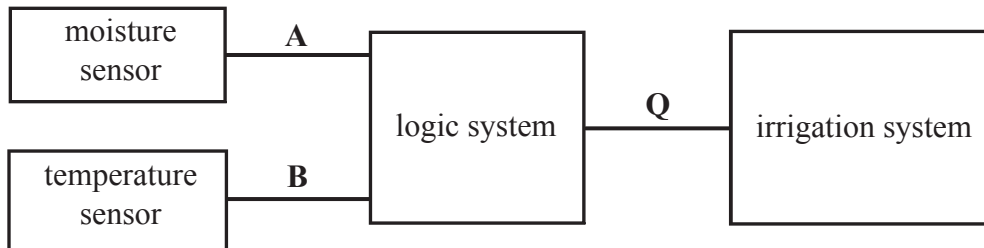

(a) Identify the key component of the temperature sensor. [1]

.....
.....

(b) Complete the truth table for the logic system. [2]

A	B	Q
0	0	
0	1	
1	0	
1	1	

(c) Draw the circuit diagram for the logic system. [3]



B2. (a) Solar cells can be used to charge batteries during the day to provide light at night. One such system charges 6 volt batteries. Calculate the power delivered to a torch bulb if the battery supplies 2 amperes. [1]

.....
.....

(b) Identify the likely outcome if a 4 volt torch bulb were to be connected to the charged battery by mistake. [2]

.....
.....
.....



B3. **Figure B2** shows the input to a logic system used in a temperature control system for a smart home. **Figure B3** shows the characteristics of thermistor X.

Figure B2: Input to a logic system for a temperature control system in a smart home

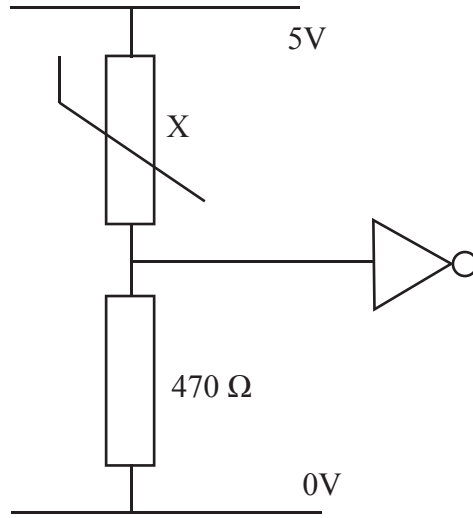
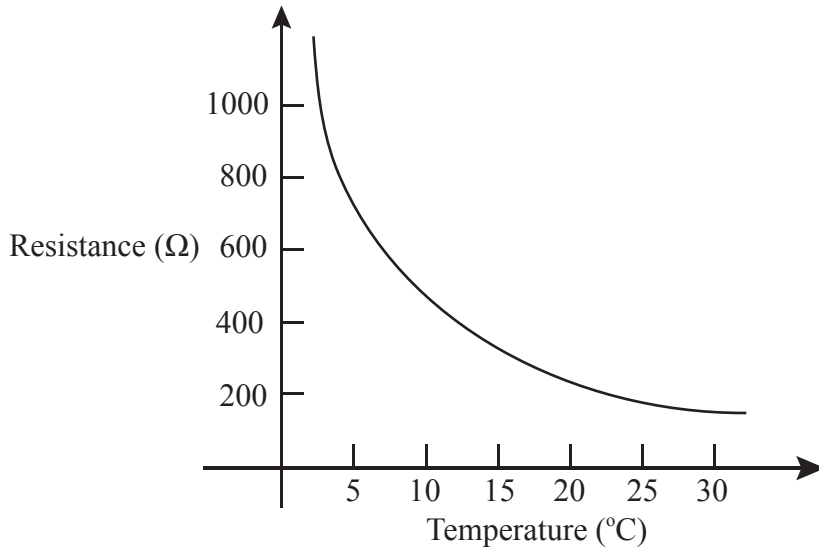

Figure B3: The characteristics of thermistor X in Figure B2



(a) State the resistance of thermistor X at 10°C. [1]

.....
.....

(b) Explain why thermistor X can be used to provide logic 0 when the temperature rises above approximately 10°C in the logic system shown in Figure B2. [3]

.....
.....
.....
.....



B4. Outline **one** reason why only a fraction of the capacity of a PIC is used in many electronic products. [2]

.....
.....
.....

B5. Explain how a digital hearing aid can be customized to meet the requirements of an individual user initially and through its product lifecycle. [6]

.....
.....
.....
.....
.....
.....
.....
.....
.....
.....
.....



Blank page



Option C — CAD / CAM

C1. **Figure C1** shows a wardrobe that was supplied as a flat-pack for self assembly. The pack includes all the necessary components and instructions for assembly. The instructions use exploded drawings of sections of the wardrobe.

Figure C1 (a): Self-assembly wardrobe

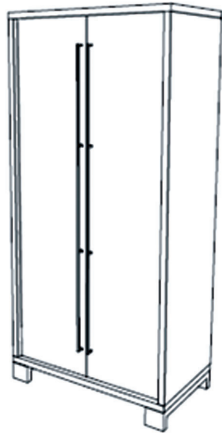

Figure C1 (b): Knock-down fittings



Figure C1(c): Assembly instructions

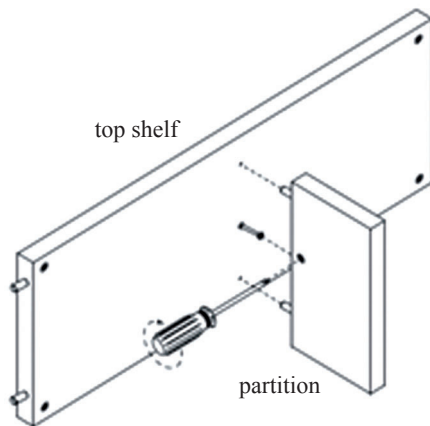
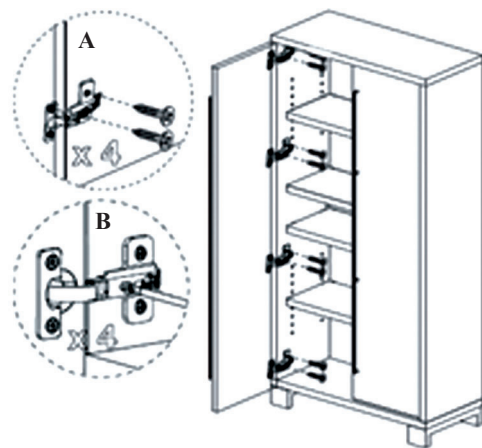

Figure C1 (d): Assembly instructions



[Source: www.cb2.com/assembly/cadet_wardrobe.pdf]

(a) State **one** benefit for the consumer of using knock-down (KD) fittings in the design of the wardrobe in Figure C1.

[1]

.....
.....

(This question continues on the following page)



(Question C1 continued)

- (b) Describe how the exploded drawing in Figure C1 will help consumers to assemble the wardrobe. [2]

.....
.....
.....

- (c) Discuss **one** advantage of using CAM in the manufacture of flat-pack furniture. [3]

.....
.....
.....
.....

- C2.** (a) State the term given to the manufacturing of 3D parts by depositing molten material in a series of layers. [1]

.....
.....

- (b) Describe a context where a laser cutter could be used to manufacture parts. [2]

.....
.....
.....



C3. Figure C2 shows different views of a ring produced using CAD.

Figure C2: CAD image of a ring



[Source: www.compufield.com]

(a) Outline how the use of CAD has simplified the designing of jewelry. [2]

.....
.....
.....

(b) Outline how a scanner could be used to aid jewelry design using CAD. [2]

.....
.....
.....

C4. List **two** issues for manufacturers when choosing CNC equipment. [2]

.....
.....
.....

C5. Figure C3 shows a CAD image of the housing for an electronic product.

Figure C3: CAD image of the housing for an electronic product

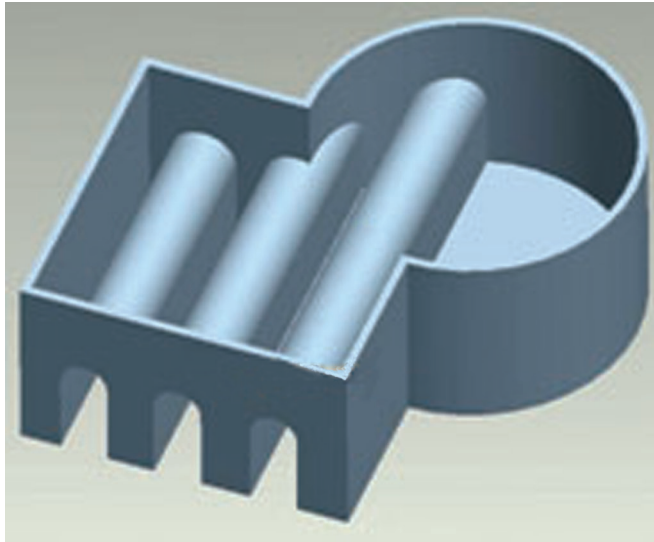

Discuss **two** limitations of using 3-axis machining to make the product in Figure C3.

[6]

.....

.....

.....

.....

.....

.....

.....

.....

.....

.....



Option D — Textiles

D1. Speedo, a company producing swimwear, has invested in research to design fabrics that are able to enhance the performance of competitive swimmers by reducing drag as they move through the water. **Figure D1** shows a bodysuit made of Fastskin® – a biomimetic fabric. Fastskin® has “super-stretch” characteristics which improve shape retention and increase muscle compression to reduce vibration and retain muscle shape, reducing fatigue and power loss. Fastskin® is a composite of polyamide, a synthetic textile fibre, and Lycra®. The bodysuit has to fit like a second skin and is made in a range of sizes to ensure it fits well (see **Figure D2**).

Figure D1: Speedo bodysuit



Figure D2: Measuring for a bodysuit

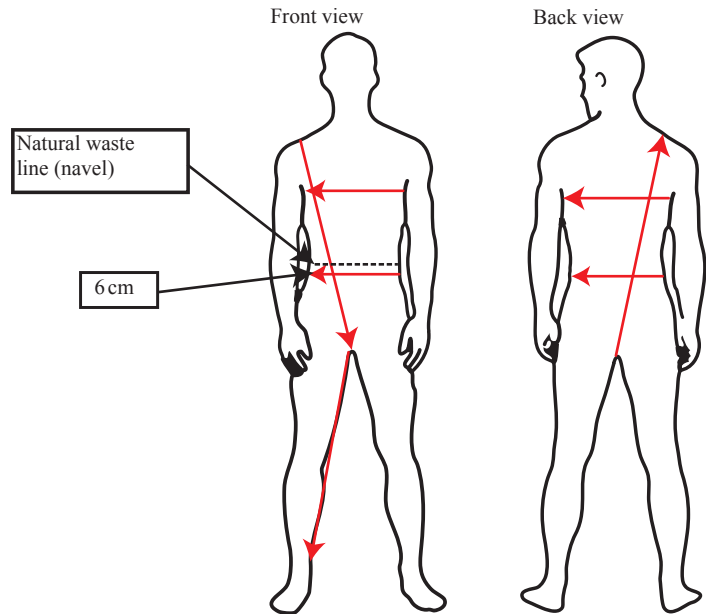

[Source: Copyright Speedo International. Reproduced with permission]

(a) Define *biomimetic*. [1]

.....
.....

(b) Outline **one** reason why the bodysuit has to fit like a second skin. [2]

.....
.....
.....

(This question continues on the following page)



(Question D1 continued)

(c) Explain **one** reason why a composite material is used for the manufacture of Fastskin®. [3]

.....
.....
.....
.....

D2. (a) Define *brand*. [1]

.....
.....

(b) Outline **one** strategy which would contribute to the development of a brand. [2]

.....
.....
.....



D3. **Figure D3** shows a 6-needle embroidery system suitable for small-scale commercial use and for education. The embroidery system has a range of inbuilt designs and users can create their own designs on a PC and transfer them to the system for sewing.

Figure D3: 6-needle embroidery system



[Source: Image source – Brother Industries Ltd Nagoya, Japan]

(a) Describe the market for products developed using the embroidery system. [2]

.....
.....
.....

(b) Outline **one** way in which the embroidery system can help to enhance designer-client relationships. [2]

.....
.....
.....



D4. Outline **one** negative impact of product branding of textile garments on the health of adolescents. [2]

.....
.....
.....

D5. Discuss **two** advantages using SMART textiles in cars. [6]

.....
.....
.....
.....
.....
.....
.....
.....
.....
.....



Option E — Human factors design

E1. Figure E1 is a paper prototype of a page set up from Microsoft Word, a word processing programme.

Figure E1: Paper prototype

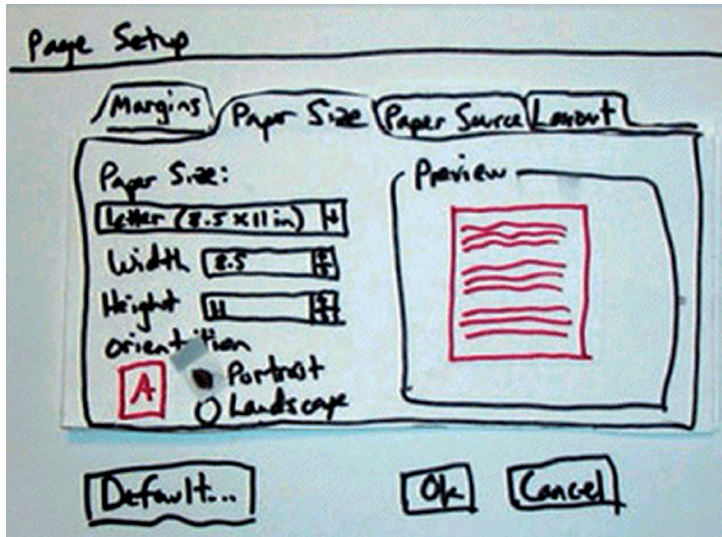

[Source: http://www.snyderconsulting.net/article_paperprototyping.htm]

(a) State **one** advantage of paper prototyping. [1]

.....
.....

(b) Outline **one** way in which paper prototyping can be seen as an example of participatory design. [2]

.....
.....
.....

(c) Explain the role of the user in a paper prototyping session. [3]

.....
.....
.....
.....



E2. (a) State the measurement scale used for dates, *e.g.* 2010, in the Western world. [1]
.....
.....

(b) Outline why a comfort rating scale of 1–10 is an ordinal scale. [2]
.....
.....
.....



E3. Figure E2 shows the use of work triangles in a kitchen layout design.

Figure E2: Work triangles in a kitchen layout design

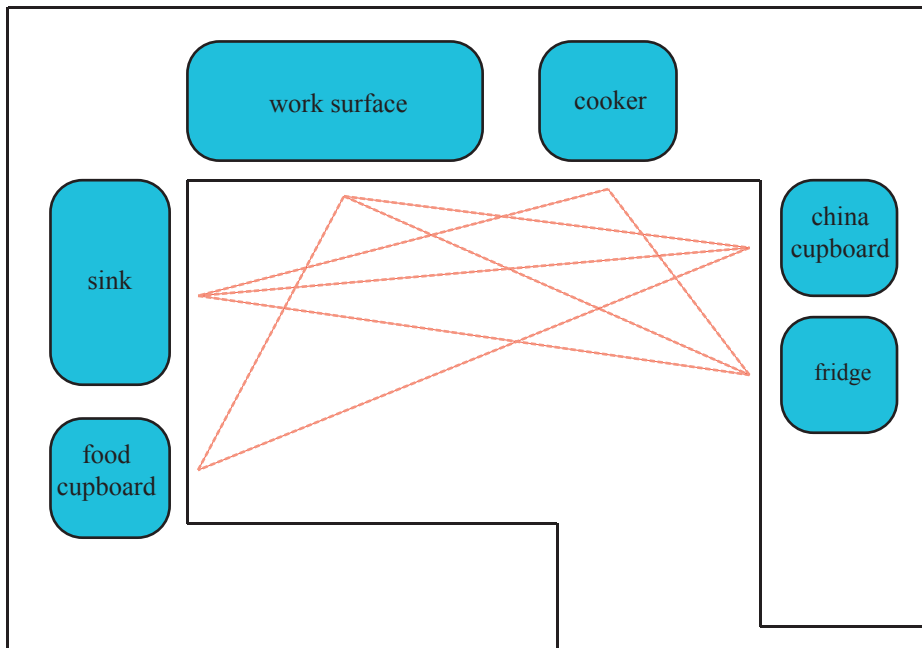

(a) Describe the relationship between work triangles to kitchen layout design. [2]

.....
.....
.....

(b) Outline how the use of a work triangle may assist a designer to resolve safety issues in the design of a kitchen layout. [2]

.....
.....
.....

E4. Describe **one** reason why a designer would use an appearance prototype at the design development stage of a product. [2]

.....
.....
.....

E5. **Figure E3** shows three possible layouts for a cooker hob with four burners and four control knobs.

Figure E3: cooker hob layouts

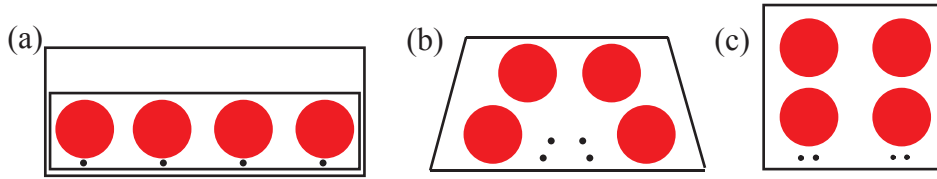

Discuss **two** issues for the designer in deciding which layout should be adopted as the standard design.

[6]

.....

.....

.....

.....

.....

.....

.....

.....

.....

.....

.....

